



Engine

Model	Cummins 6BTA5.9-C173
Type	Direct injection, turbocharged, water cooled
Rated power	126KW
Rated speed	2200rpm

Hydraulic System

Main pump	KAWASAKI
Main valve	TOSHIBA/Parker
Motor	TOSHIBA/Parker
Hydraulic flow rate	2x238L/min
Hydraulic pressure	30MPa

Operating Scope

Stick length	3000mm
A: Max. cutting height	9650mm
B: Max. dumping height	7150mm
C: Max. digging depth	7050mm
D: Max. reach	10400mm

Main Technical Specification

Operating weight	23000Kg
Standard bucket capacity	1.0m ³
Slewing speed	13rpm
Stick digging force	109KN
Bucket digging force	135.9KN

Travelling System

Travelling speed	3~5km/h
Grade ability	65%
Ground pressure	0.045MPa

Main Features

- Dual hydraulic pump system
- Advanced electrical system
- Advanced ground pressure reducer
- Special preferential hydraulic system
- Ergonomically designed cab

Main Applications

- Hydro-electric project
- Small-scale mining
- Road construction
- City dwellings construction
- Sea port and airport
- Road repairing project

Dimensions

Overall length	9845mm
Overall width	3000mm
Overall height of boom	3300mm
Overall height of cab	2755mm
Engine cover height	2300mm
Counterweight clearance	1060mm
Ground clearance	465mm
Upperstructure width	2710mm
Rear-end length/Slewing radius	2940mm
Overall track length	4510mm
Track length on ground	3720mm
Track gauge	2400mm
Track width	600mm
Boom slewing angle(L/R)	0°

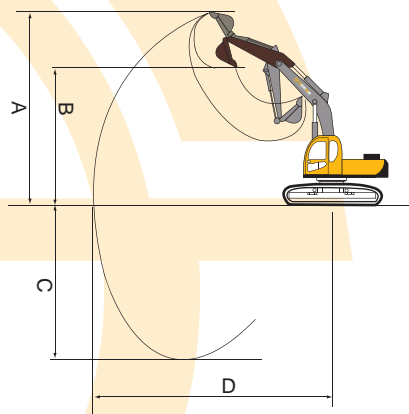

Optional

- Hydraulic breaker
- Quick hitch